

ALBA STANDARD GRAVITY ROLLER CONVEYOR

Model No. 297SS

WHEN ORDERING SPECIFY:

297SS-XX-XX-XX-XX

- BETWEEN FRAMES
- ROLLER CENTERS
- ROLLER SETTING IN FRAME
- LENGTH

Specify "SC" for Curve Section

Equipment Specifications

- Length:** Standard 5' & 10' sections
- Width:** Effective widths available from 6" to 63" (in 1" increments)
- Rollers:** 2-9/16" Diameter x 7 Gauge Wall
- Axles:** 11/16" Hex Axles, Spring Retained
- Centers:** 3", 4-1/2", 6", 9" & 12"
- Capacity:** 850 lbs. per roller
- Bearings:** Integral labyrinth, sealed ball bearing, zinc plated, grease packed
- Frames:** 4 @ 5.4# Structural channel
- Supports:** Heavy duty, fabricated from 3" @ 4.1# channel legs 1-1/2 x 1-1/2 x 1/4 angle welded cross ties Adjustable foot, ± 2-1/2"
- Paint:** Alba standard blue

STANDARD Rollers set 1/8" high

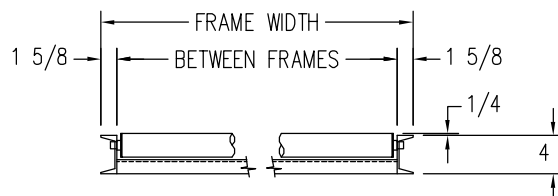

OPTIONAL Rollers set 3/4" low

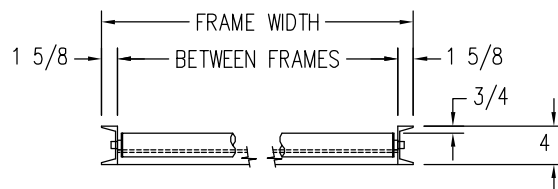

Between Frames	Inside Radius	90° Curve		45° Curve	
		Rollers Per Curve	Roller Pattern	Rollers Per Curve	Roller Pattern
13	32-1/2	18	Single	9	Single
15	32-1/2	18	Single	9	Single
17	32-1/2	18	Single	9	Single
19	32-1/2	18	Single	9	Single
21	32-1/2	18	Single	9	Single
23	32-1/2	18	Double	9	Double
25	32-1/2	18	Double	9	Double
27	48	18	Double	9	Double
31	48	40	Double	20	Double
33	48	40	Double	20	Double
37	48	40	Double	20	Double
39	48	40	Double	20	Double
43	48	40	Double	20	Double
51	48	40	Double	20	Double
54	48	40	Double	20	Double

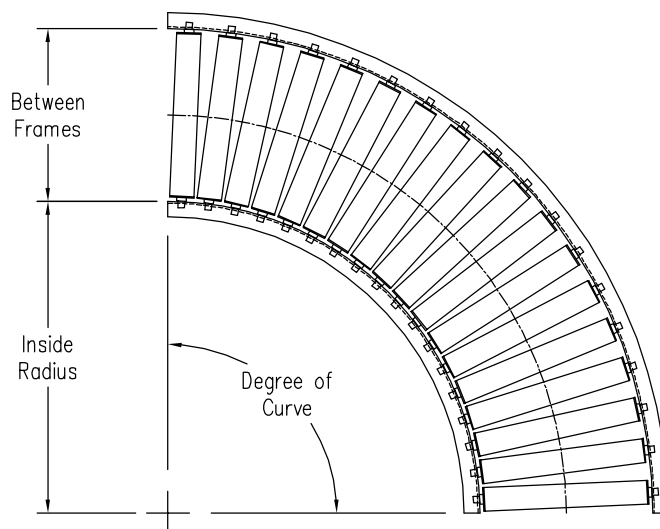

ALBA STANDARD CHAIN DRIVEN LIVE ROLLER (Model #297SS)

ROLLER CENTERS	"A"	"B"	"C"	"D"
3	60	1-1/2	(19) spaces	54
4-1/2	58-1/2	2-1/4	(12) spaces	52-1/2
6	60	3	(9) spaces	54
9	54	4-1/2	(5) spaces	48-1/2
12	60	6	(4) spaces	54

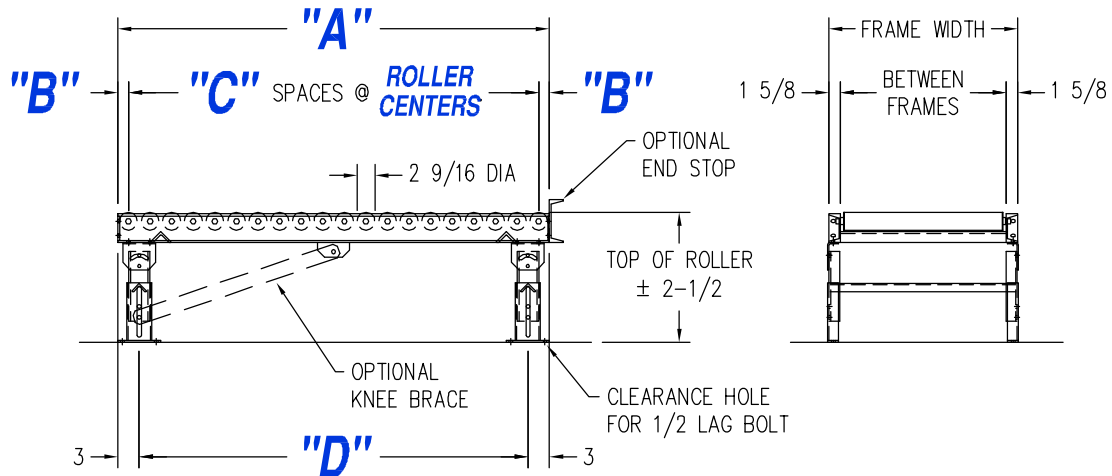
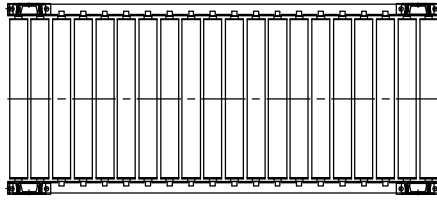

ROLLER CENTERS	"A"	"B"	"C"	"D"
3	120	1-1/2	(39) spaces	57
4-1/2	117	2-1/4	(25) spaces	55-1/2
6	120	3	(20) spaces	57
9	117	4-1/2	(13) spaces	55-1/2
12	120	6	(9) spaces	57

