

ALBA GRAVITY ROLLER CONVEYOR

Model No. 3509SS

Gravity Conveyor - 3-1/2 dia x 9 gauge rollers

WHEN ORDERING SPECIFY:

3509SS-XX-XX-XX-XX

- BETWEEN FRAMES
- ROLLER CENTERS
- ROLLER SETTING IN FRAME
- LENGTH

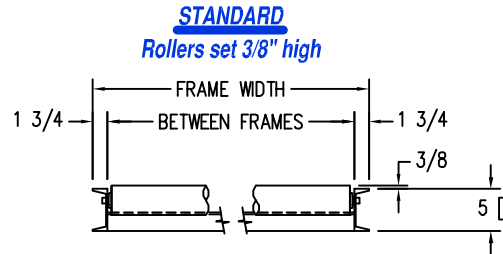

Length: Nominal 5' & 10' sections

Width: Between frame available up to 66"

Rollers: 3-1/2" diameter x 9 gauge wall, 11/16" hex axles, spring retained, light oiled ball bearings

Centers: 4-1/2", 6", 9", 12"

Capacity: 850 Lbs. per roller

Frame: 5 @ 6.7# channel with 2 x 2 x 1/4 angle cross ties, welded construction

Supports: Heavy duty, fabricated from 4 @ 5.4# channel legs, 3 @ 4.1# channel welded cross ties, adjustable foot, ± 2-1/2"

Paint: Alba blue

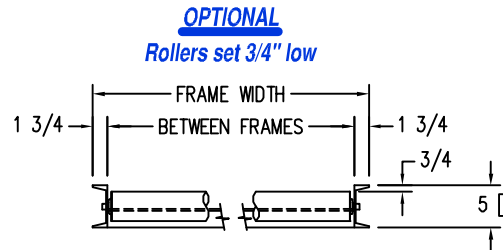

MOVE IT

on Conveyors by ...

Alba

MANUFACTURING, INC.

ALBA MODEL #3509SS GRAVITY ROLLER CONVEYOR

ROLLER CENTERS	"A"	"B"	"C"	"D"
4-1/2	58-1/2	2-1/4	(12) spaces	52-1/2
6	60	3	(9) spaces	54
9	54	4-1/2	(5) spaces	48-1/2
12	60	6	(4) spaces	54

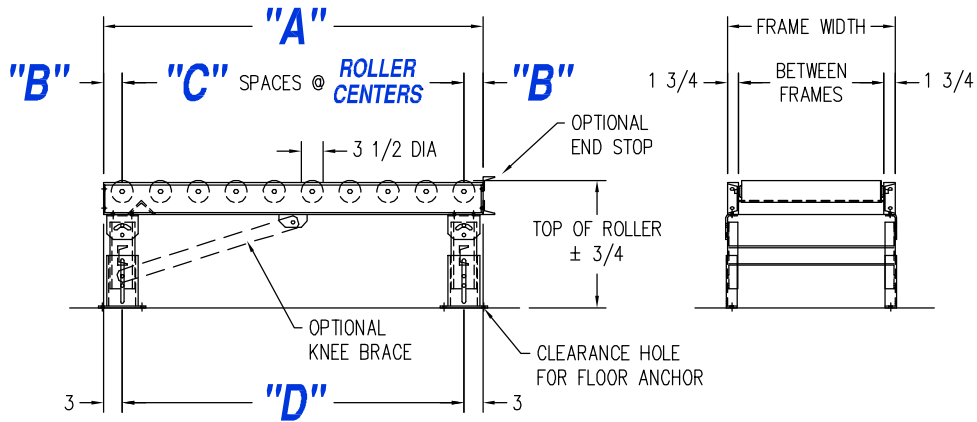
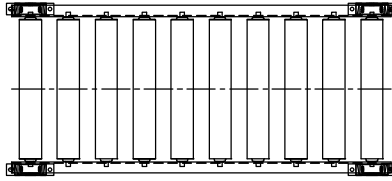

ROLLER CENTERS	"A"	"B"	"C"	"D"
4-1/2	117	2-1/4	(25) spaces	55-1/2
6	120	3	(20) spaces	57
9	117	4-1/2	(13) spaces	55-1/2
12	120	6	(9) spaces	57

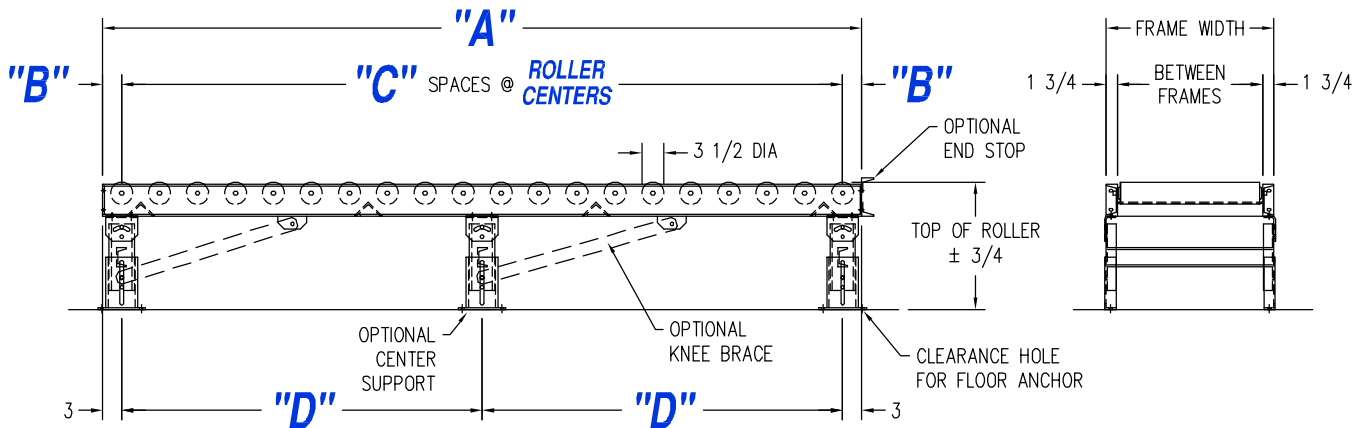
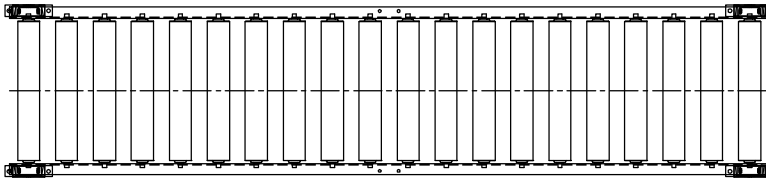

MOVE IT
on Conveyors by ...



MANUFACTURING, INC.