

# ALBA STANDARD 2-STRAND DRAG CHAIN CONVEYOR

## Model No. DC-R80-2S-X-X-XX-XX

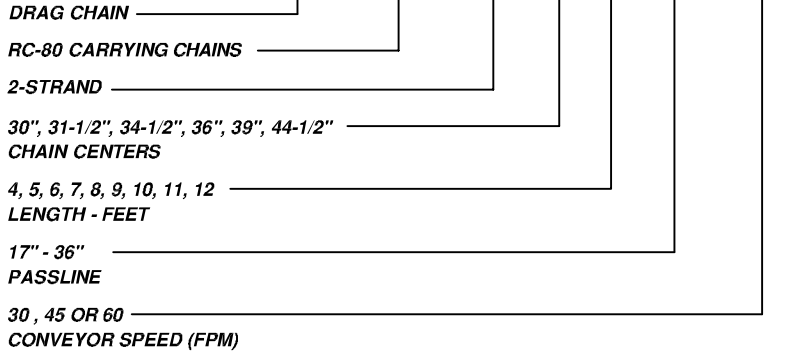

## STANDARD SPECIFICATIONS

- DRAG CHAIN FRAME:** #7GA FORMED FRAME RAILS, STRUCTURAL STEEL SUPPORTS & CROSS MEMBERS, ALL WELDED CONSTRUCTION.
- CARRYING CHAINS:** RC80 SINGLE STRAND RIVETED ROLLER CHAIN.
- CHAIN GUIDES:** MACHINED UHMW WEARSTRIP.
- DRIVE:** CENTER DRIVE WITH BALDOR C-FRAME MOTOR, 230/460/3/60, AND SHAFT MOUNTED GEAR REDUCER.
- OPTIONS:** TREADPLATES BETWEEN CHAINS  
VFD RATED MOTORS  
GUIDE RAILS  
PHOTO EYES

PLEASE CONSULT THE FACTORY WITH YOUR APPLICATION FOR PROPER DRIVE SIZING.

