

# ALBA STANDARD TURNTABLE TOP - 2.75 ROLLER CENTERS

## Model No. TT251140-2.75-DBS

### Chain Driven Live Roller Conveyor Turntable Top - 2.75" Roller Centers Driven Both Sides, Rc40 Roll to Roll Chains

**Rollers:** 2-1/2" Diameter x 11 Gauge Wall, 11/16" Hex Axles, Spring Retained, Two (2) #40A21 Sprockets, Grease Packed Ball Bearings

**Setting:** Rollers are set 7/8" low both sides

**Paint:** Alba standard blue with safety yellow chain guards

**Frame:** 5" @ 6.7# Channel both sides

**Drive:** Standard C-Frame Motor and Gear Reducer 230/460/3/60, Rc40 Drive Chain

**Elevation:** 17" min. tor with pneumatic base and 18" tor with electric base

**Roller**

**Capacity:** Bed Rollers - 850 Lbs. Each  
Drive Rollers - 2,100 Lbs. Each

**Speeds:** 30, 45 or 60 FPM, Fixed

**Option:** Transition roller stands

### WHEN ORDERING SPECIFY:

- MODEL#
- EFFECTIVE WIDTH
- HORSEPOWER
- SPEED
- BASE STYLE (ELECTRIC OR PNEUMATIC)
- TOP OF ROLLER ELEVATION
- OPTIONS

#### AVAILABLE EFFECTIVE WIDTHS

EFFECTIVE WIDTH	TABLE DIAMETER
44"	72"
48"	75"
52"	78"
54"	78"
60"	86"

**Please consult the factory with your application for proper drive sizing.**

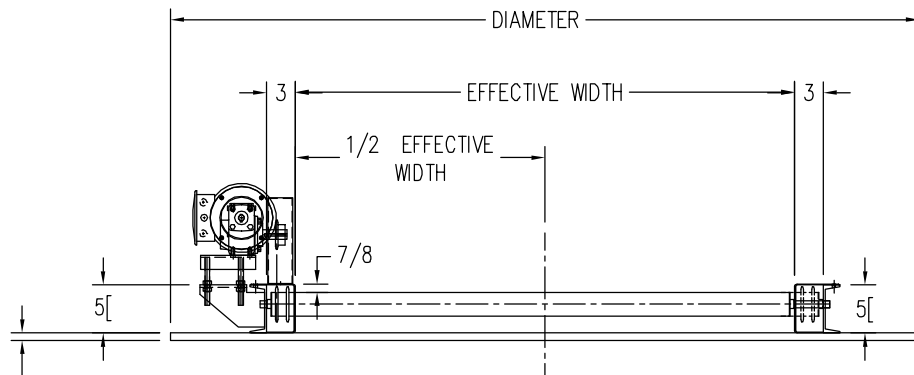
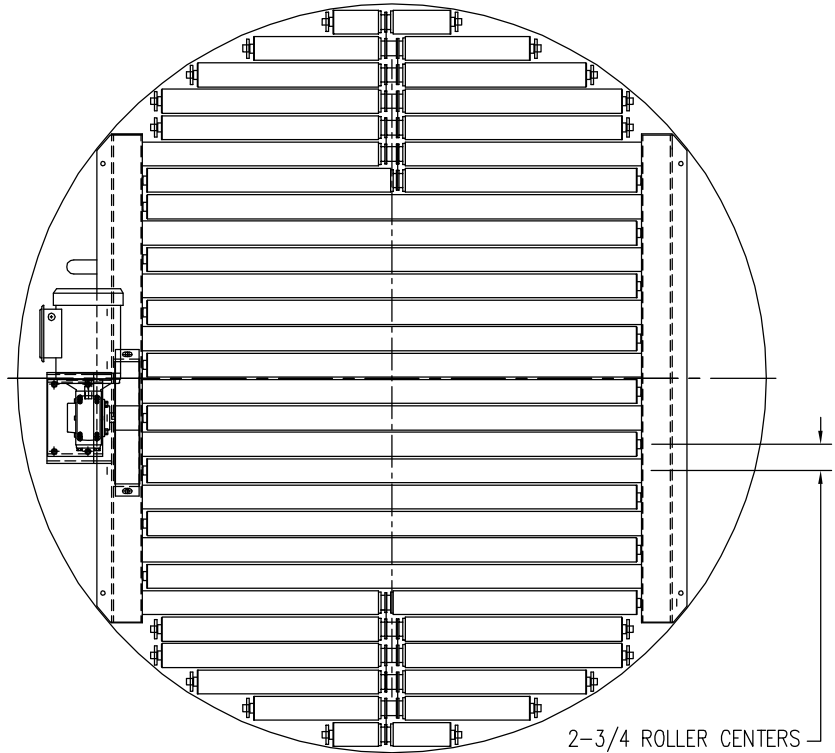

3/4" w/ ELECTRIC BASE  
1/2" w/ PNEUMATIC BASE