

ALBA STANDARD TURNTABLE TOP - 4.00 ROLLER CENTERS

Model No. TT251140-4

Chain Driven Live Roller Conveyor Turntable Top - 4.00" Roller Centers Rc40 Roll to Roll Chains

Rollers: 2-1/2" Diameter x 11 Gauge Wall, 11/16" Hex Axles, Spring Retained, Two (2) #40A21 Sprockets, Grease Packed Ball Bearings

Frame: 6" @ 8.2# Channel driven side
4" @ 5.4# Channel non-driven side

Roller

Capacity: Bed Rollers - 850 Lbs. Each
Drive Rollers - 2,100 Lbs. Each

Setting: Rollers are set 1-7/8" low drive side and 1/4" high non-drive side

Drive: Standard C-Frame Motor and Gear Reducer 230/460/3/60, Rc40 Drive Chain

Speed: 30, 45 or 60 FPM, Fixed

Paint: Alba standard blue with safety yellow chain guards

Elevation: 17" min. tor with pneumatic base and 18" tor with electric base

Option: Transition roller stands

WHEN ORDERING SPECIFY:

- MODEL#
- EFFECTIVE WIDTH
- HORSEPOWER
- SPEED
- BASE STYLE (ELECTRIC OR PNEUMATIC)
- TOP OF ROLLER ELEVATION
- OPTIONS

AVAILABLE EFFECTIVE WIDTHS

EFFECTIVE WIDTH	TABLE DIAMETER
44"	72"
48"	78"
52"	78"
54"	86"
60"	86"

Please consult the factory with your application for proper drive sizing.

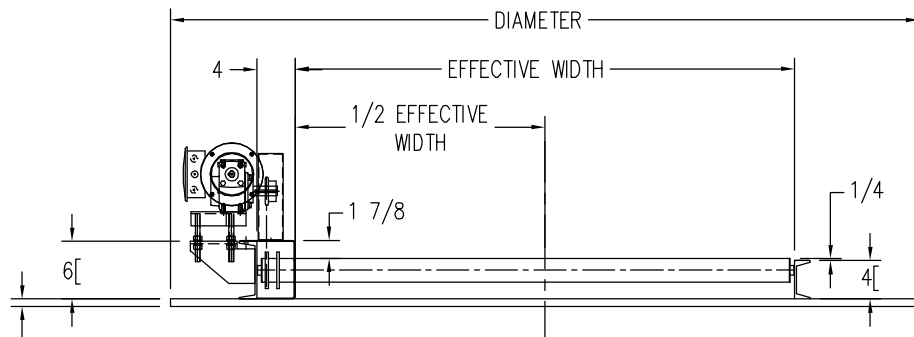
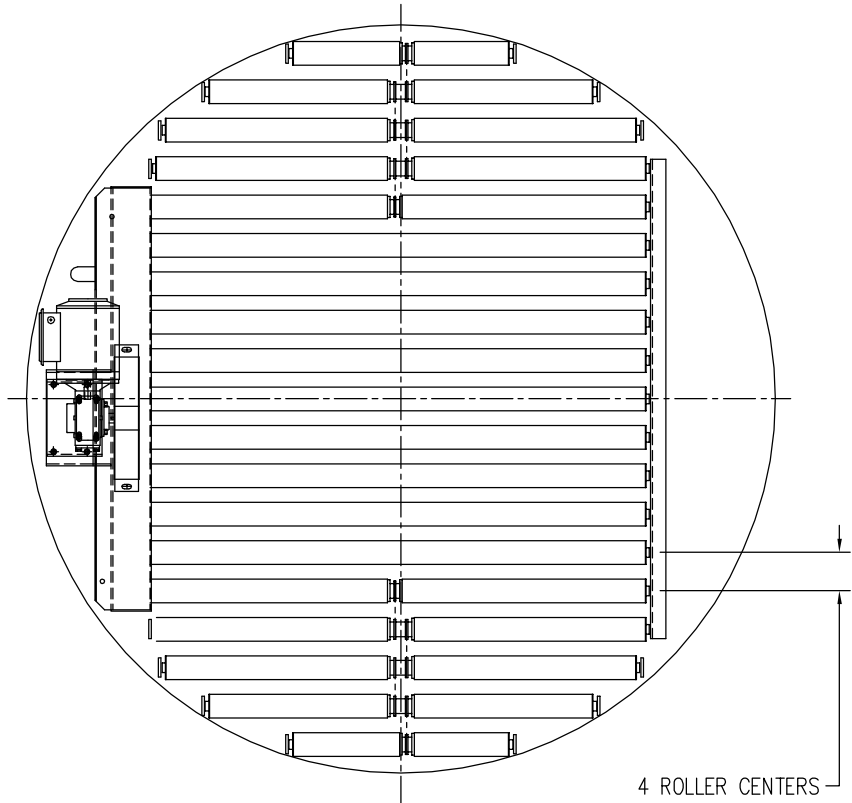

3/4" w/ ELECTRIC BASE
1/2" w/ PNEUMATIC BASE