

# ALBA STANDARD TURNTABLE TOP - 4.50 ROLLER CENTERS

## Model No. TT251160-4.5

### Chain Driven Live Roller Conveyor Turntable Top - 4.50" Roller Centers Rc60 Roll to Roll Chains

**Rollers:** 2-1/2" Diameter x 11 Gauge Wall, 11/16" Hex Axles, Spring Retained, Two (2) #60A15 Sprockets, Grease Packed Ball Bearings

**Frame:** 6" @ 8.2# Channel driven side  
4" @ 5.4# Channel non-driven side

**Roller**

**Capacity:** Bed Rollers - 850 Lbs. Each  
Drive Rollers - 2,100 Lbs. Each

**Setting:** Rollers are set 1-7/8" low drive side and 1/4" high non-drive side

**Drive:** Standard C-Frame Motor and Gear Reducer 230/460/3/60, Rc60 Drive Chain

**Speed:** 30, 45 or 60 FPM, Fixed

**Paint:** Alba standard blue with safety yellow chain guards

**Elevation:** 17" min. tor with pneumatic base and 18" tor with electric base

**Option:** Transition roller stands

### WHEN ORDERING SPECIFY:

- MODEL#
- EFFECTIVE WIDTH
- HORSEPOWER
- SPEED
- BASE STYLE (ELECTRIC OR PNEUMATIC)
- TOP OF ROLLER ELEVATION
- OPTIONS

#### AVAILABLE EFFECTIVE WIDTHS

EFFECTIVE WIDTH	TABLE DIAMETER
44"	72"
48"	78"
52"	82"
54"	86"
60"	86"

**Please consult the factory with your application for proper drive sizing.**

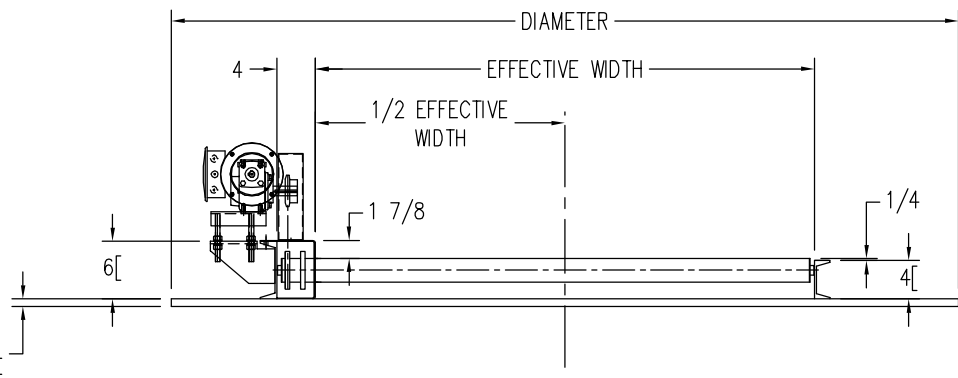
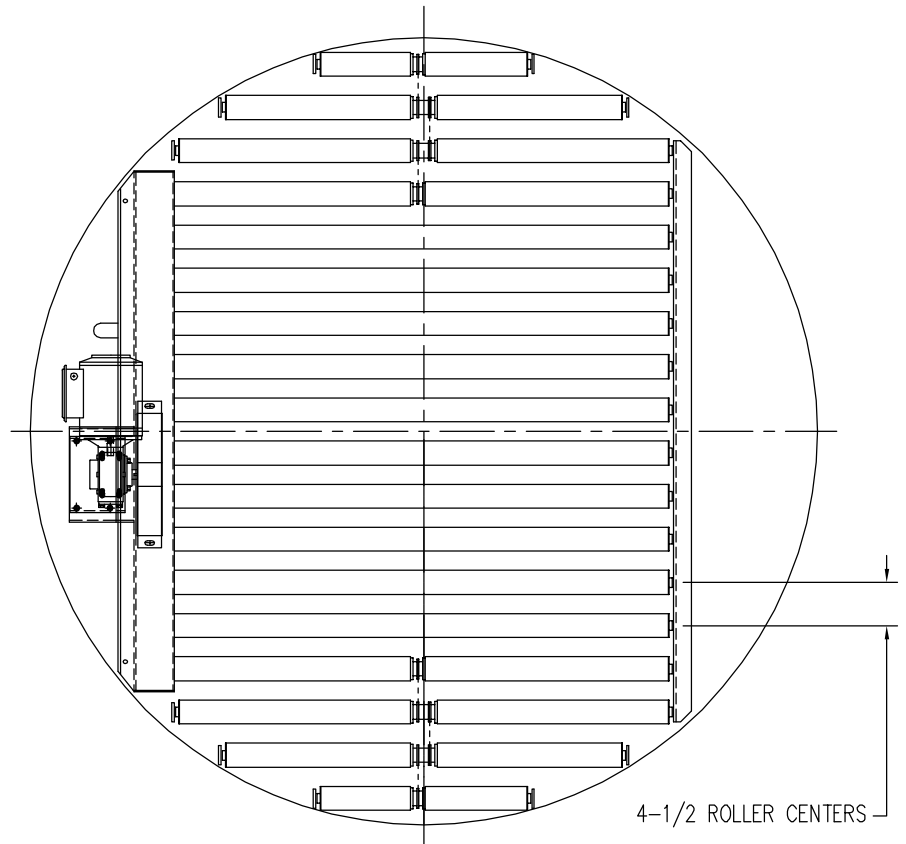

3/4" w/ ELECTRIC BASE  
1/2" w/ PNEUMATIC BASE